

SECTION A-A

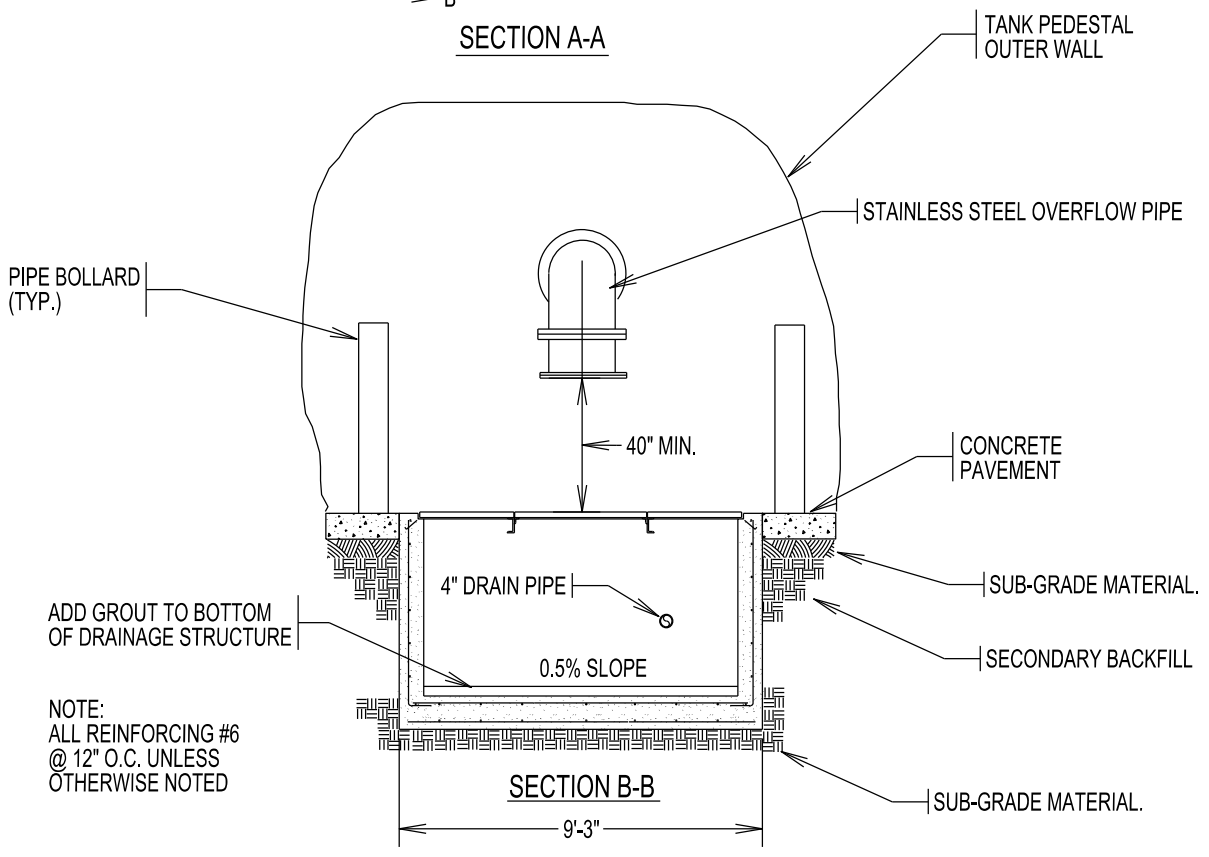

SECTION B-B

DD-903-09

SAN ANTONIO WATER SYSTEM
SAN ANTONIO, TEXAS



APPROVED:
MARCH 2011

SHEET
2 OF 2

TANK OVERFLOW/DRAINAGE STRUCTURE

REVISED: