

San Antonio Water System Standard Specifications for Construction

ITEM NO. 834

Fire Hydrants

834.1 DESCRIPTION: This item shall consist of fire hydrant installations using joint restraints in accordance with these specifications and as directed by the Engineer.

834.2 REFERENCED STANDARDS Reference standards cited in this Specification Item No. 834 refer to the current reference standard published at the time of the latest revision date.

1. San Antonio Water System (SAWS):
 - a. Specifications for Water and Sanitary Sewer Construction
 - b. SAWS Materials Specifications
2. City of San Antonio (COSA) Standard Specification for Construction
3. Texas Commission of Environmental Quality (TCEQ)
 - a. TCEQ 290 Rules and Regulations for Public Regulations for Public Water Systems
4. American Water Works Association (AWWA)
 - a. AWWA C 502 – Standard for Dry Barrel fire Hydrants
 - b. AWWA C 550 - Standard for Protective Epoxy Interior Coatings for Valves and Hydrants
5. Society of Protective Coatings
 - a. SSPC SP2 - Hand Tool Cleaning
 - b. SSPC SP3 - Power Tool Cleaning
 - c. SSPC SP10 - Near-White Blast Cleaning
 - d. SSPC SP11 - Power Tool Cleaning to Bare Metal
 - e. SSPC 36 – Two-Component Weatherable Aliphatic Polyurethane Topcoat, performance based
 - f. SSPC 42 – Epoxy Polyamide/Polyamidoamine Primer, performance based

834.3 MATERIALS: The materials for fire hydrant installations shall conform to the specifications contained within the latest revision of SAWS' Material Specification Item No. 95-10, "Specifications of Pipe Joint Restraint Systems," Item No. 113-02, "Ductile Iron Restrained Joint Fittings for Use on Ductile Iron," and Item No. 21-30, "Fire Hydrants."

1. PVC pipe is not allowed.
2. **Only ductile iron pipe shall be allowed for fireline services.**
3. Upper and lower stems shall be 316 stainless steel.
4. The exterior of the hydrant shall be shop coated by manufacturer.

834.4 CONSTRUCTION: Hydrants shall be connected to mains as shown in the contract documents or as directed by the Engineer.

1. Hydrants shall be installed in accordance with Standard Drawings DD-834 Drawing Series.
2. See drawings for required depth and offsets detail.
3. Hydrants greater than 6 ft bury will not be allowed.

San Antonio Water System Standard Specifications for Construction

4. Hydrants shall also be installed in a location where there is accessibility and in a safe location where there is a minimum possibility of damage from vehicles or injury to pedestrians.
5. One (1) foot fire valve extension is allowed.
6. In situations where hydrants are placed directly behind curbs, hydrant barrels shall be set so that no portion of the hydrant will be less than 12 inches nor more than 7 feet from the back of the curb.
7. Where hydrants are set in the lawn spaces between the curb and the sidewalk or between the sidewalk and the property line, no portion of the hydrant or nozzle cap shall be within 6 inches of the sidewalk.
8. Setting final grade of fire hydrants to match proposed or existing field conditions is the responsibility of Contractor.
9. Hydrants shall be set in accordance with Standard Drawings DD-834-Drawing Series and shall be set plumb and shall have their nozzles parallel with, or at right angles to, the curb with the pumper nozzle facing the curb.
10. Drainage and concrete pads shall be provided at the base of hydrants as specified.
11. No fire hydrant drainage system or pit shall be connected to a storm or sanitary sewer.
12. The Contractor shall install anchored or flanged style fittings in accordance with Standard Drawings DD-834 Drawing Series.
13. Restrained Joints: Restrained mechanical joints that require field welding or groove cuts into the pipe barrel for restraint will not be accepted.
14. Restrained joints shall be furnished for pipe at all changes in direction as indicated in the contract documents, or as directed by the Engineer.
15. Restrained mechanical joints shall be locked mechanical joints.
16. All joints shall conform to the SAWS' Material Specification Item No. 95-10, "Pipe Joint Restraint Systems."
17. The restraint system shall be capable of a test pressure twice the maximum sustained working pressure of 350 psi for ductile iron pipe.
18. Replacing and Relocating Existing Fire Hydrants: When existing fire hydrants are to be replaced or relocated, the work shall be accomplished by either of the following:
 - a. Cutting or installing a tee of the size and type as indicated in the contract documents or as directed by the Engineer.
 - b. Using a tapping sleeve and valve of the size and type as indicated in the contract documents to install a new fire hydrant to an existing or new water main. Size on size taps will not be permitted.
 - c. Relocating the existing fire hydrant by closing the existing fire hydrant branch valve, removing the existing fire hydrant, extending the fire hydrant branch and installing the existing fire hydrant as specified herein.
 - d. Solid sleeve will be required for all relocating of branches.
 - e. The Contractor shall salvage the existing fire hydrants and other materials as designated in the field by the Inspector and shall deliver this material to the SAWS materials storage yard indicated on the contract documents.

San Antonio Water System Standard Specifications for Construction

- f. Fire hydrant branches shall be abandoned by cutting and capping or plugging the fire hydrant cast iron tee at the service main and the surface restored to its original condition.
- 19. Installation on Water Mains: Ductile iron pipe, cast iron and ductile iron fittings, and valves used in the placement of fire hydrants and connections to the main will be considered part of the fire hydrant installation and not a part of the main construction.
 - a. No separate payment will be made for this pipe. Hydrants shall be connected to the mains as shown in the contract documents or as directed by the Engineer.
 - b. Hydrants shall also be installed in a location where there is accessibility and in a safe location where there is a minimum possibility of damage from vehicles or injury to pedestrians.
- 20. Operation of hydrant shall be full closed or full open. Throttling is prohibited.

834.5 MEASUREMENT: Standard Fire Hydrants with 6 inch Valve and Box will be measured by the unit of each fire hydrant, valve, and box installed. Relocate Fire Hydrants will be measured by the unit of each fire hydrant relocated. Standard Fire Hydrants with Tapping Sleeve, 6 inch Valve, and Box will be measured by the unit of each fire hydrant, including the various sizes of tapping sleeves, valves and boxes installed.

834.6 PAYMENT: Payment of the following bid pay items shall include: excavation, backfill, selected material, anti-corrosion embedment when specified, hauling and disposition of surplus excavated materials, backfill, branch line pipe, nipples, and fittings exclusive of the tee from the main line pipe, polyethylene sleeve where required, asphalted material for ferrous surfaces, joint restraints, concrete pad, guard post, restoration of existing fire hydrant sites and removal and relocation of existing fire hydrant as specified.

- 1. Fire hydrant painting shall be subsidiary to all fire hydrant payment item(s). No separate payment will be made for fire hydrant painting.
- 2. Plugging, capping, and removal of an existing fire hydrant are incidental to work performed for a fire hydrant.
- 3. Materials paid on site will be in accordance with Table 1 of Specification Item No. 100 Mobilization.

PAY ITEM No. 834.1 – Fire Hydrant: Installation of a new fire hydrant as specified in the contract documents and as specified herein for a fire hydrant with 6 inch valve and box.

PAY ITEM No. 834.2 – Tapped Fire Hydrant: Payment for installation of a new fire hydrant by tapping an existing or new water main as specified in the contract documents and as specified herein for a Fire Hydrant with tapping sleeve, 6 inch valve and box. No size on size taps will be allowed.

PAY ITEM No. 834.3 – Relocate Fire Hydrant: Payment for relocating a fire hydrant shall include relocating an existing fire hydrant to a new location as specified in the contract documents and as specified herein. Restoration of the existing fire hydrant site shall be inclusive to this line item.

San Antonio Water System Standard Specifications for Construction

-End of Specification-

NOTE:

Use:

(A) Anchoring Tee with M.J. Fitting or M.J. Valve

(B) Std. M.J. Tee with Anchoring Coupling or Anchoring Fitting

NOTE:

Polywrap Below Ground

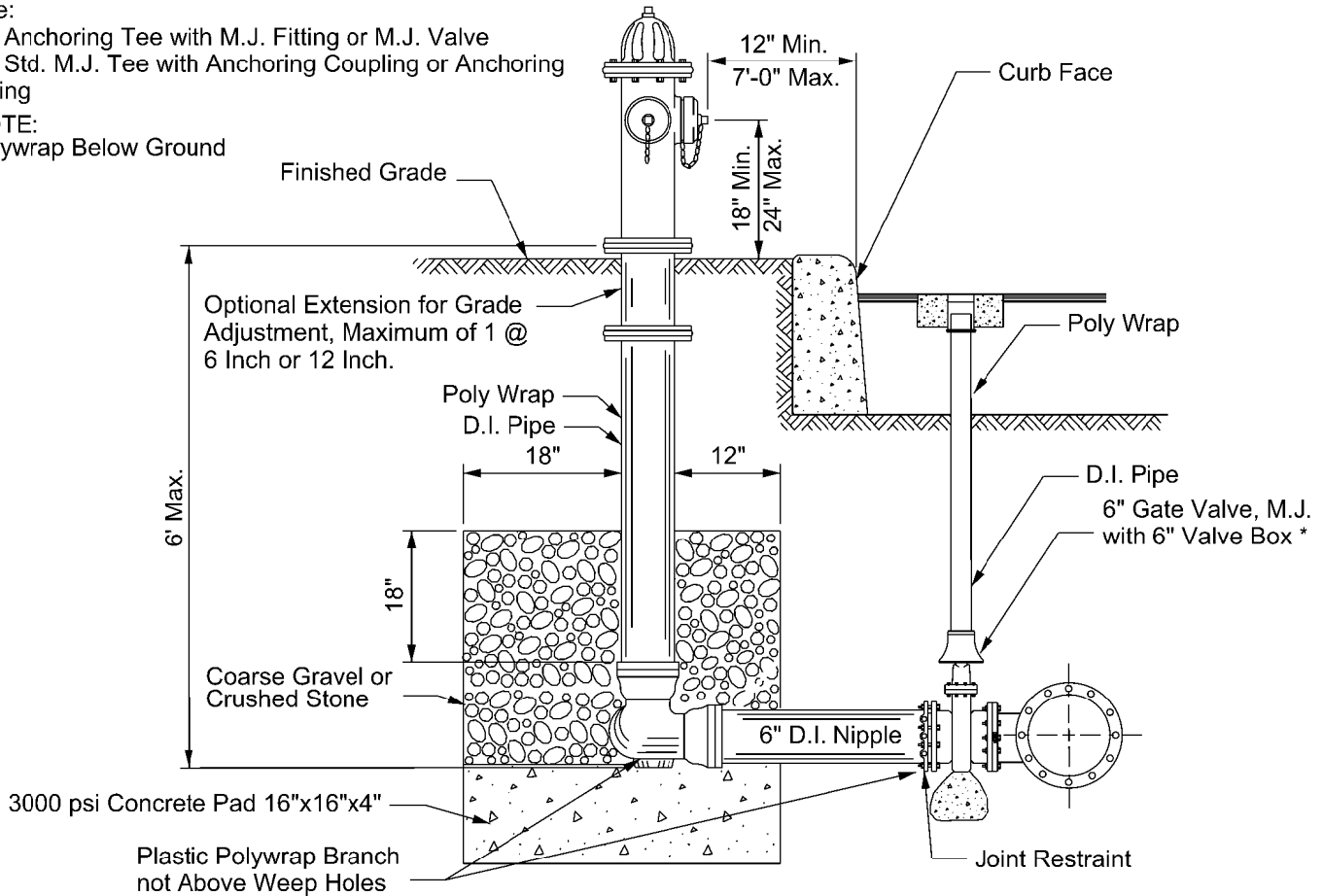

PREFERRED INSTALLATION
Profile Shown without Horizontal Bend

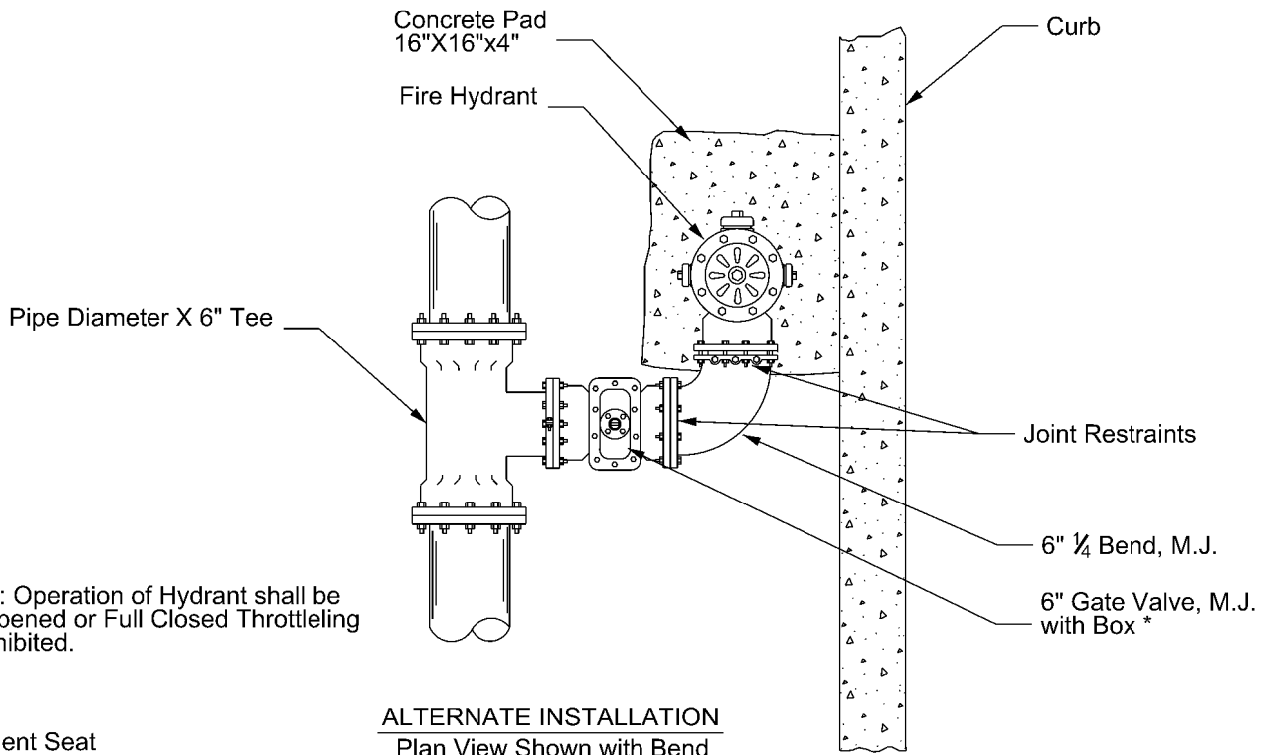

NOTE: Operation of Hydrant shall be Full Opened or Full Closed Throttling is Prohibited.

ALTERNATE INSTALLATION
Plan View Shown with Bend

* Resilient Seat

PROPERTY OF
SAN ANTONIO WATER SYSTEM
SAN ANTONIO, TEXAS

FIRE HYDRANT
INSTALLATION
(JOINT RESTRAINT)

APPROVED

MAY 2013

REVISED

AUG 2019

DD-834-01

SHEET
1 OF 3

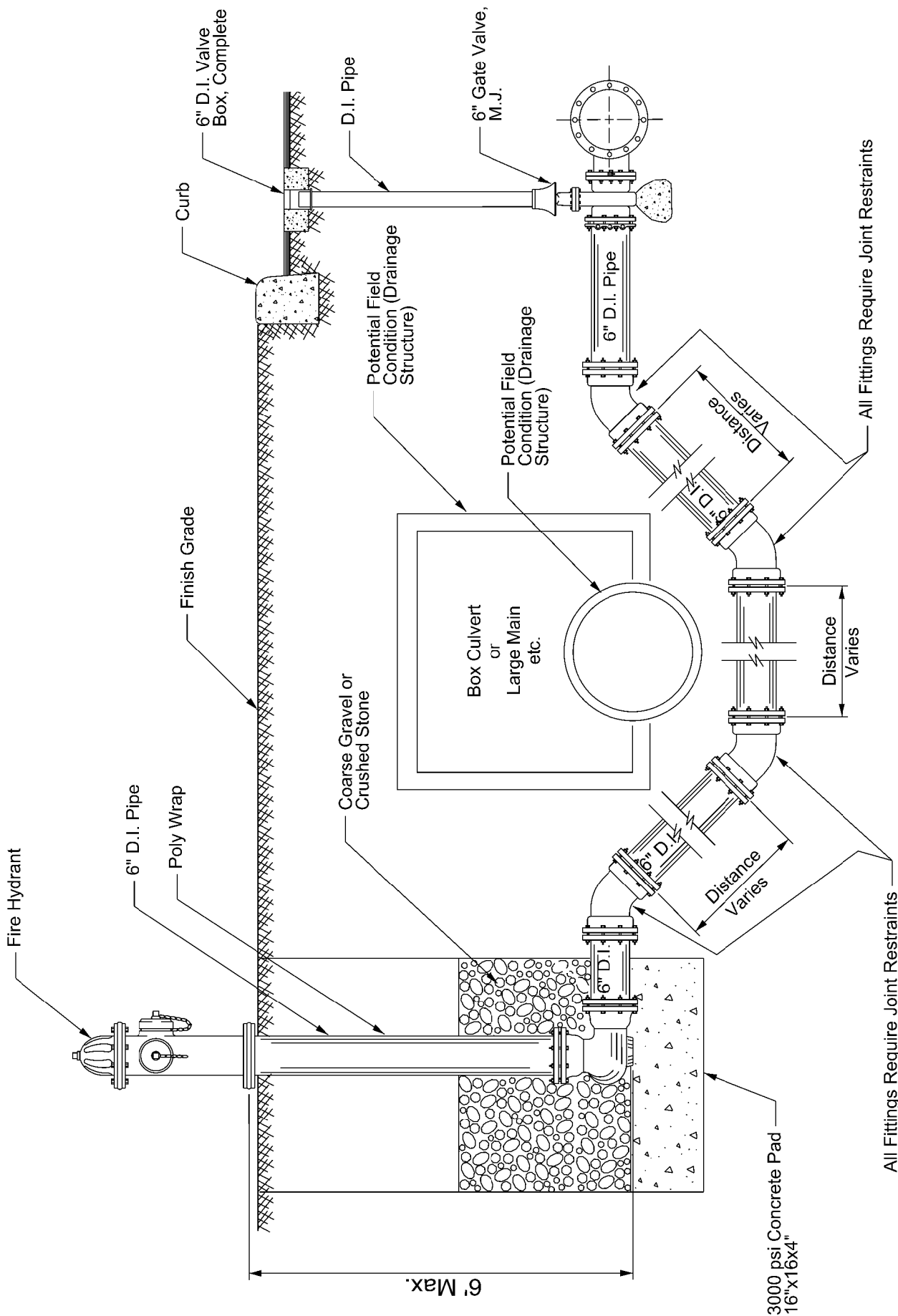

All Fittings Require Joint Restraints

Distance Varies

Distance Varies

Distance Varies

NOTE: Operation of Hydrant shall be Full Opened or Full Closed Throttling is Prohibited.

NOTE: No Extensions Allowed

PROPERTY OF
SAN ANTONIO WATER SYSTEM
SAN ANTONIO, TEXAS

FIRE HYDRANT
WITH
OFFSET

APPROVED
MAY 2013

REVISED
AUG 2019

DD-834-01

SHEET
2 OF 3

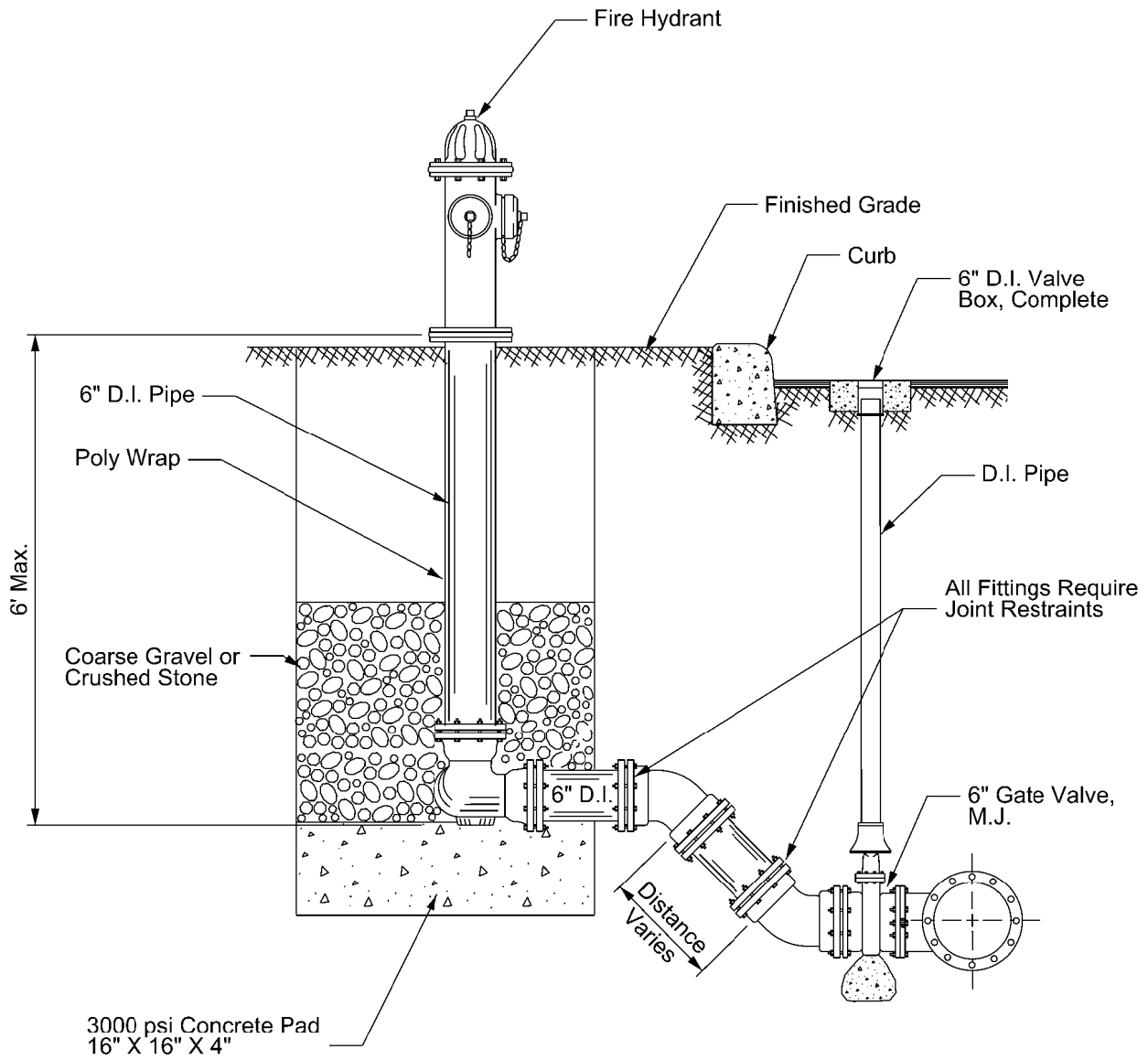

NOTE: Operation of Hydrant shall be Full Opened or Full Closed Throttling is Prohibited.

NOTE: No Extensions Allowed

PROPERTY OF
SAN ANTONIO WATER SYSTEM
 SAN ANTONIO, TEXAS

**FIRE HYDRANT
 WITH
 MAIN GREATER THAN
 6 FOOT DEPTH**

APPROVED
 MAY 2013

REVISED
 AUG 2019

DD-834-01

SHEET
3 OF 3

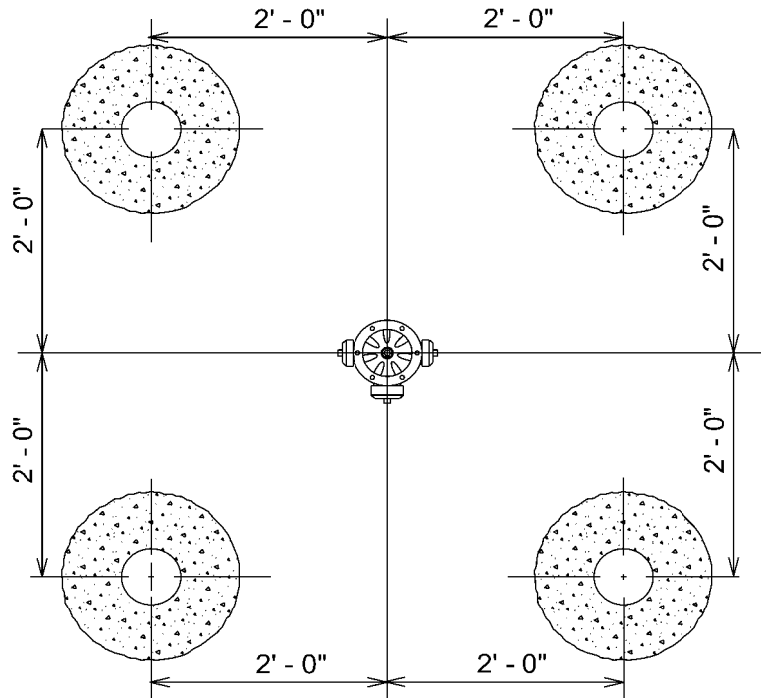

Note:
For Highway installation, see TxDOT Specifications.

Paint exposed 6" Steel pipe and Concrete Cap with one coat of rust-inhibitive primer and one coat of safety yellow paint

6" Steel pipe filled with concrete and rounded on top

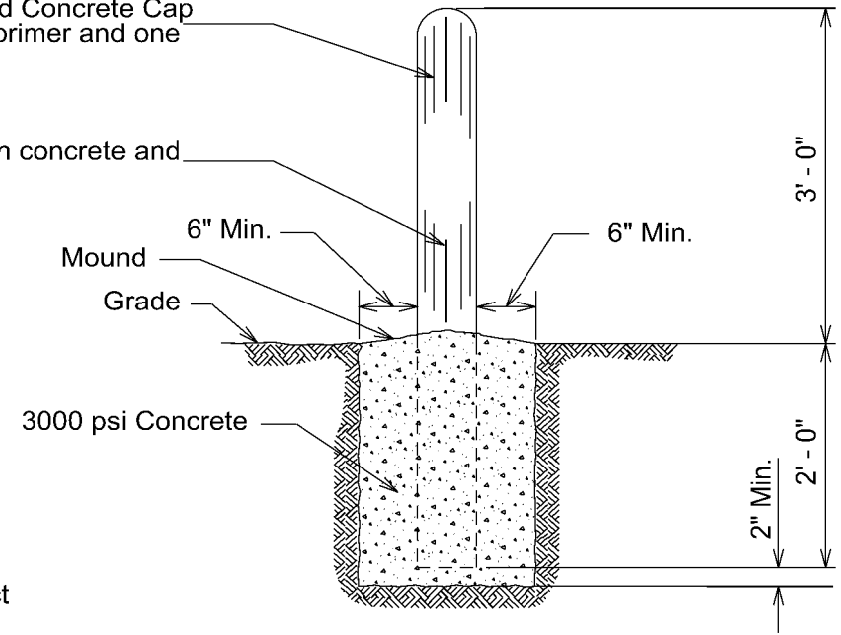

Note:
Install Guard Post as required to protect Fire Hydrant from vehicular traffic.

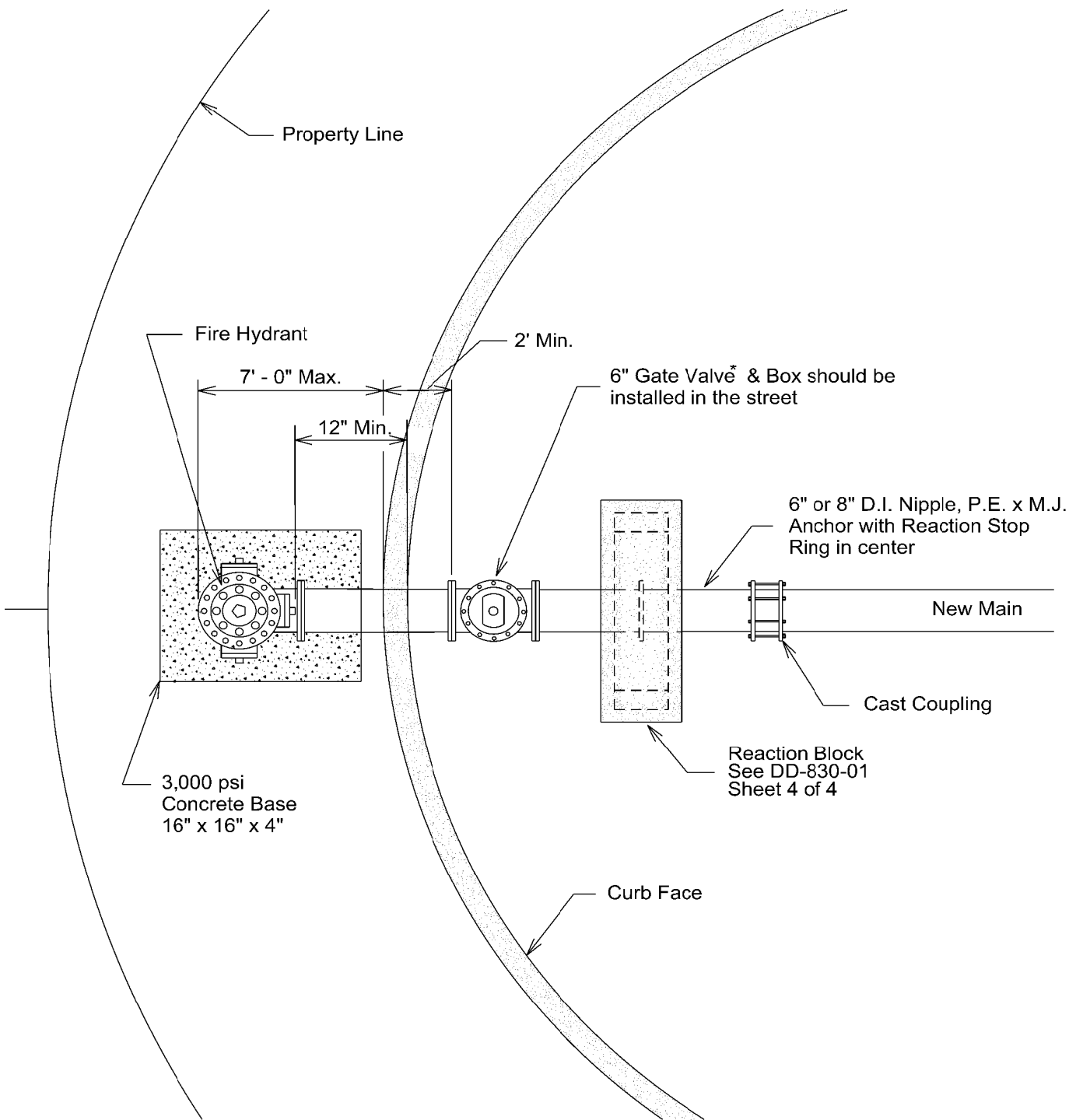

* Resilient Seat

PROPERTY OF
SAN ANTONIO WATER SYSTEM
 SAN ANTONIO, TEXAS

**FIRE HYDRANT
 INSTALLATION AT
 CUL-DE-SAC**

APPROVED
 MARCH 2008

REVISED
 AUG 2019

DD-834-03

SHEET
1 OF **2**

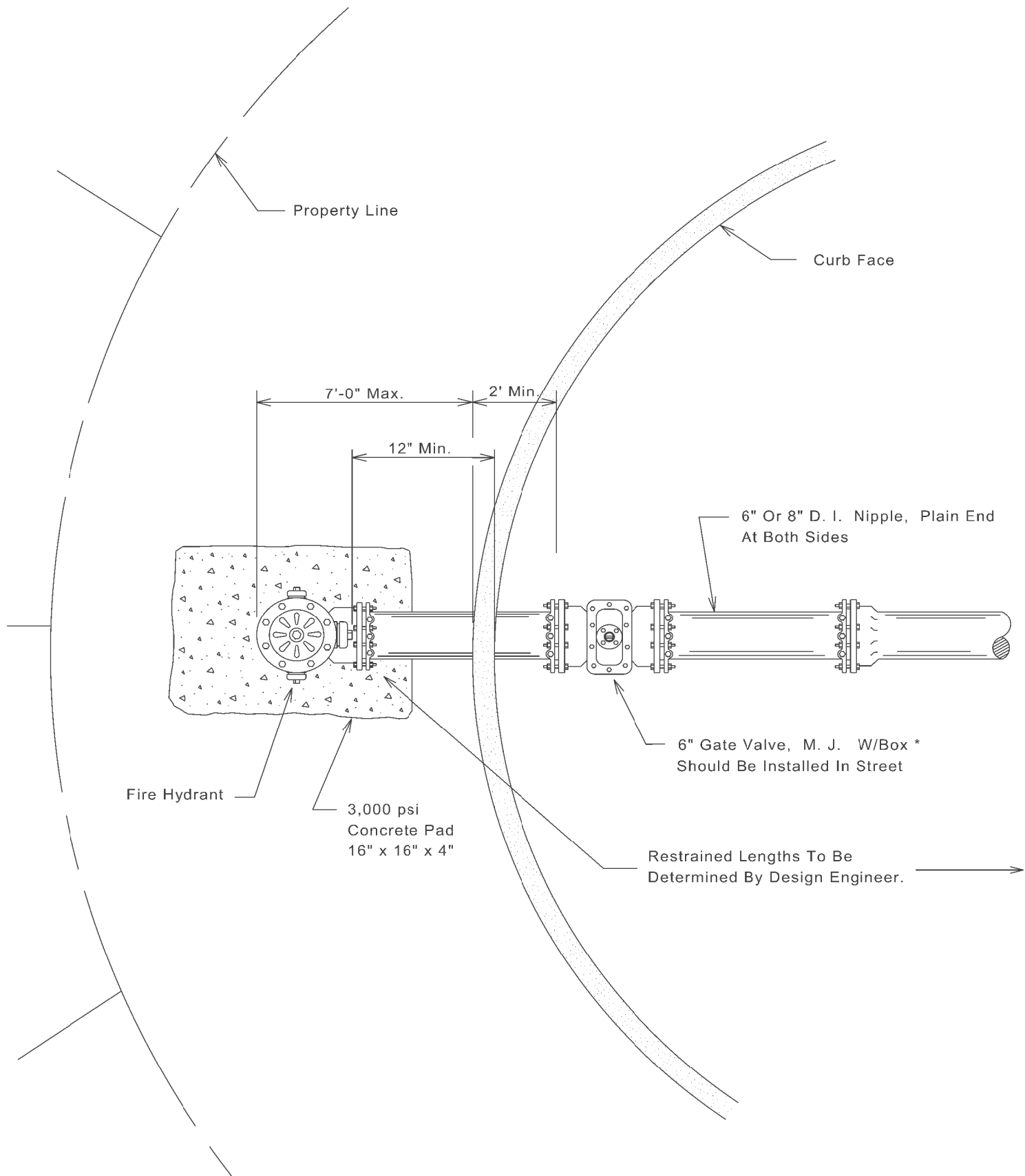

* RESILIENT SEAT

PROPERTY OF SAN ANTONIO WATER SYSTEM SAN ANTONIO, TEXAS	FIRE HYDRANT INSTALLATION AT CUL-DE-SAC (JOINT RESTRAINT)	APPROVED	REVISED
		MARCH 2008	AUG 2019
		DD-834-03	