

San Antonio Water System Standard Specifications for Construction

ITEM NO. 828

Gate Valves

828.1 DESCRIPTION: This item shall consist of gate valves installed in accordance with these specifications and as directed by the Engineer.

828.2 REFERENCED STANDARDS: Reference standards cited in this Specification Item No. 828 refer to the current reference standard published at the time of the latest revision date logged at the end of this Specification Item No. 828, unless a date is specifically cited.

1. San Antonio Water System (SAWS):
 - a. Specifications for Water and Sanitary Sewer Construction
 - b. SAWS Materials Specifications
2. City of San Antonio (COSA) Specifications for Construction
3. American Society for Testing and Materials (ASTM) International:
 - a. ASTM A 307 - Standard Specification for Carbon Steel Bolts and Studs, 60,000 psi Tensile.
 - b. ASTM B 62 - Standard Specification for Composition Bronze or Ounce Metal Casting.
 - c. ASTM D 429 - Standard Test Methods for Rubber Property-Adhesion to Rigid Substrates.
 - d. ASTM B 763 - Standard Specification for Copper Alloy Sand Casting for Valve Application.
4. American Water Works Association (AWWA)
 - a. AWWA C 500 - Standard for Metal-Seated Gate Valves for Water Supply Service.
 - b. AWWA C 509 - Standard for Resilient-Seated Gate Valves for Water Supply Service.
 - c. AWWA C 515- Standard for Reduced Wall, Resilient- Seated Gate Valves for Water Supply Service.
 - d. AWWA C 550 - Standard for Protective Epoxy Interior Coatings for Valves and Hydrants.

828.3 SUBMITTALS: Contractor shall submit manufacturer's product data, instructions, recommendations, shop drawings, and certifications. All submittals shall be in accordance with Owner's requirements and submittals shall be approved prior to delivery.

828.4 MATERIALS: The materials for all gate valves shall conform to the specifications contained within the latest revision of SAWS Material Specification Item No. 21-02, "Resilient Seated Gate Valves and Tapping Valves."

828.5 CONSTRUCTION: Gate valve installation shall include: valve, reaction blocking (conforming to Standard Drawing DD-828 series), cast iron boot, valve box extension (having ductile iron riser pipe), valve box, concrete collar and valve box lid shall be constructed with No. 3 bars all around.

1. The valve box shall be placed in such a manner to prevent shock or stress being

San Antonio Water System Standard Specifications for Construction

- transmitted to the valve.
2. All valves shall have operational nut within six feet of finish elevation.
 3. The Contractor shall install fully adjustable valve box and valve key extension systems, on all valves located between 6 feet and 13 feet.
 4. Adjustable valve box and valve key extension systems shall be centered over the valve's operating nut with the box cover flush with the finished pavement surface or located at another level as directed by the Engineer.
 5. Valve boxes located in streets or other area subject to vehicular traffic shall be provided with concrete collars as shown in these standard drawings.
 6. Collars around such valve boxes shall be formed and finished off neatly and in a sound workmanlike manner.
 7. All valves outside of pavement area maybe subject to valve marker at the direction of the inspector at no additional payment.
 8. In high pressure zones, all valves 6 inches and larger shall be supported on a concrete pad in accordance with Standard Drawings DD-828 series.

828.6 MEASUREMENT: Gate valves and valve boxes will be measured by the unit of each such assembly of the various sizes of gate valves and valve boxes installed to the finished grade.

828.7 PAYMENT: Payment for gate valves, complete with valve box, will be made at the unit price bid for each assembly of the various sizes of gate valves and valve boxes installed. Payment shall also include: excavation, selected embedment material, anti-corrosion embedment, hauling, and disposition of excavated surplus material, backfill, concrete collar at the valve box (where subjected to vehicular traffic), riser pipe, cast iron boot, packing, tar paper, concrete grout, concrete reaction blocking, protective coating material for bolts, nuts, ferrous surfaces, valve marker, and polyethylene sleeve.

End of Specification -

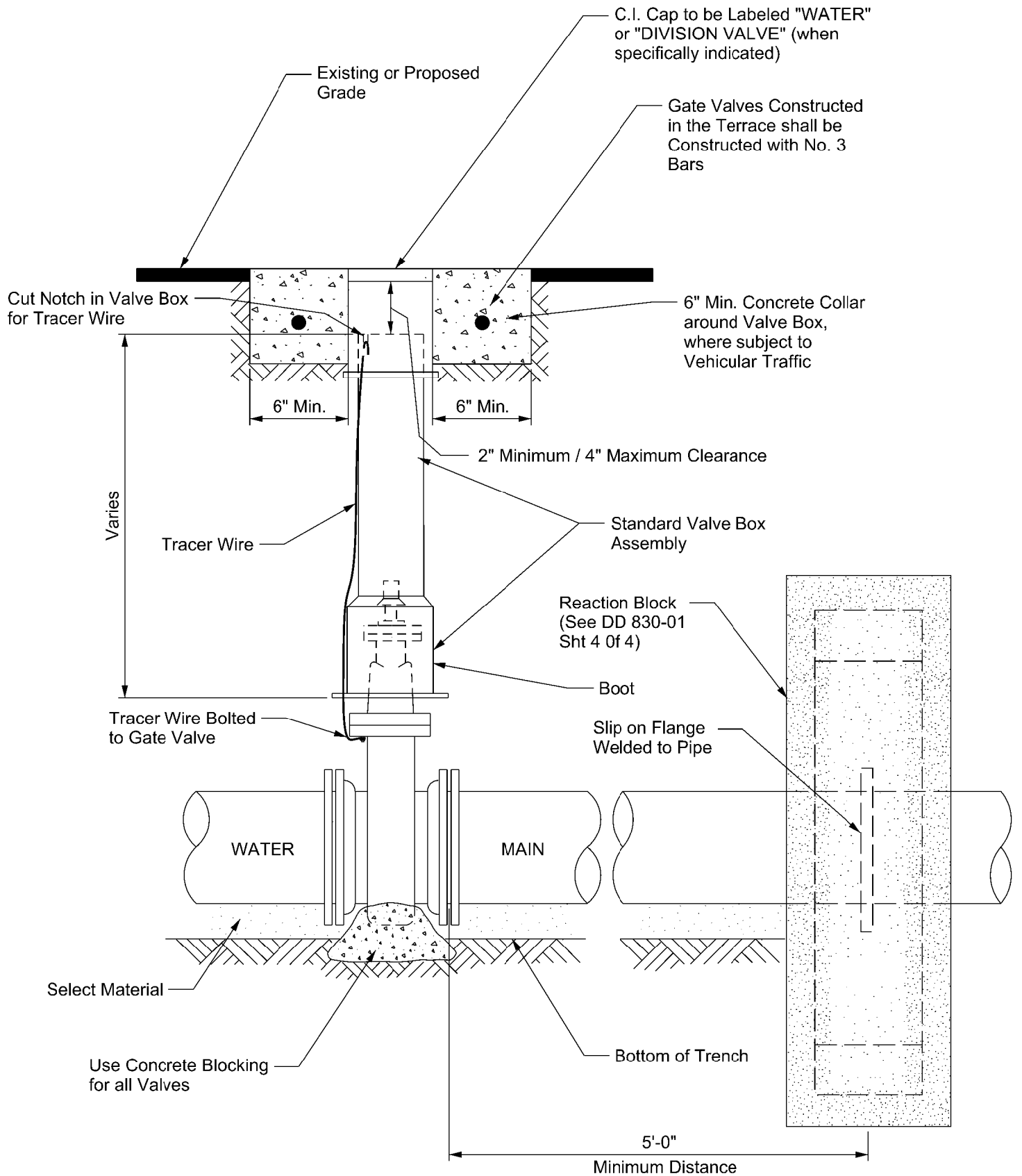

NOTE: Tracer Wire for PVC (Typ. for PVC & HDPE)
 NOTE: All Concrete to be 3,000 psi

Note: For all work associated with Recycled Water Valves, refer to DD 110-10, Sht. 1 of 1

PROPERTY OF SAN ANTONIO WATER SYSTEM SAN ANTONIO, TEXAS	INSTALLATION OF NON-GEARED GATE VALVE WITH VALVE BOX AND EXTENSION	APPROVED	REVISED
		MARCH 2008	AUG 2019
DD 828-01			SHEET <u>1</u> OF <u>1</u>

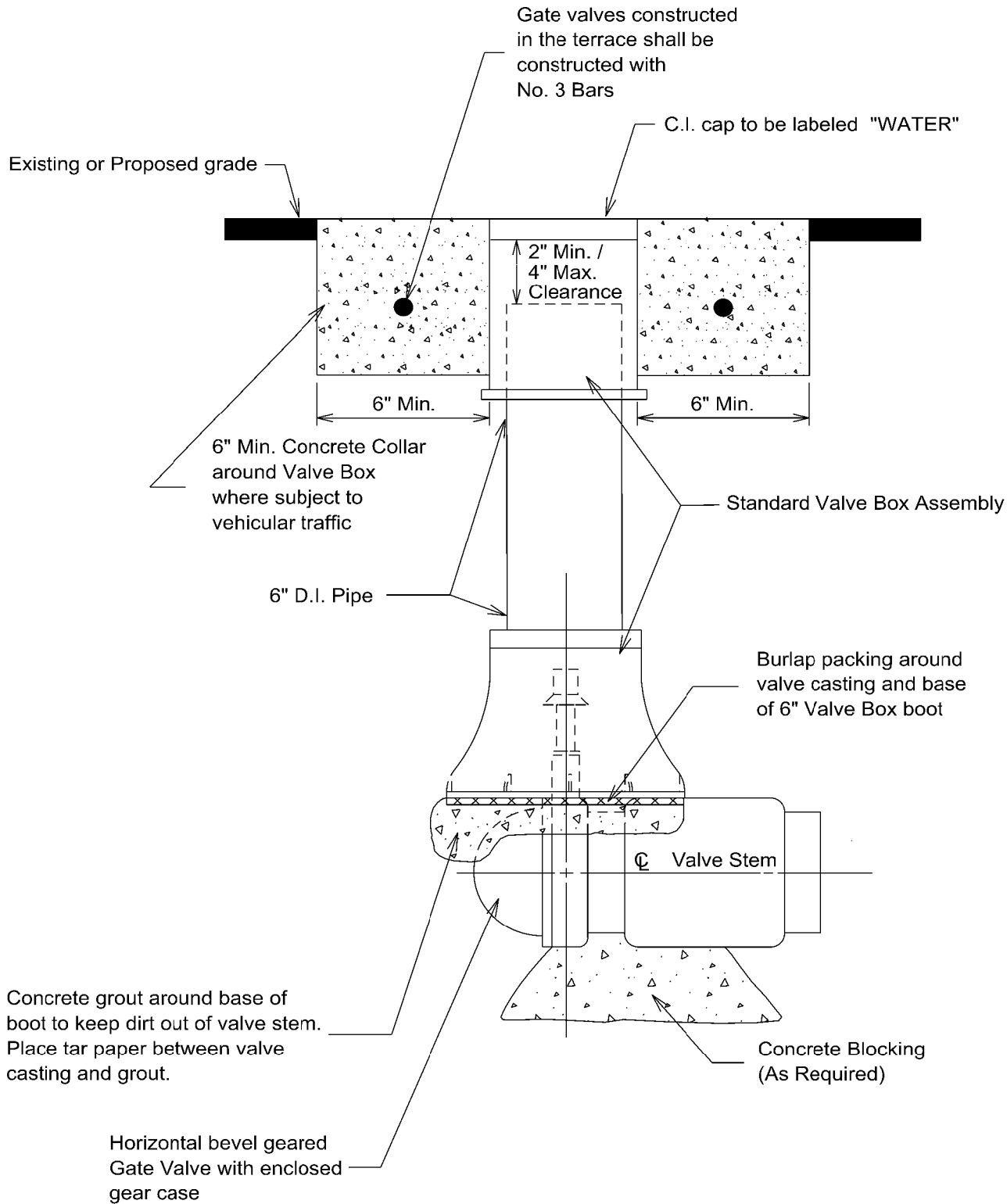

Note: All Concrete to be 3,000 psi.

PROPERTY OF SAN ANTONIO WATER SYSTEM SAN ANTONIO, TEXAS	INSTALLATION OF GEARED HORIZONTAL GATE VALVE WITH VALVE BOX COMPLETE	APPROVED	REVISED
		MARCH 2008	AUG 2019
		DD-828-02	SHEET 1 OF 1

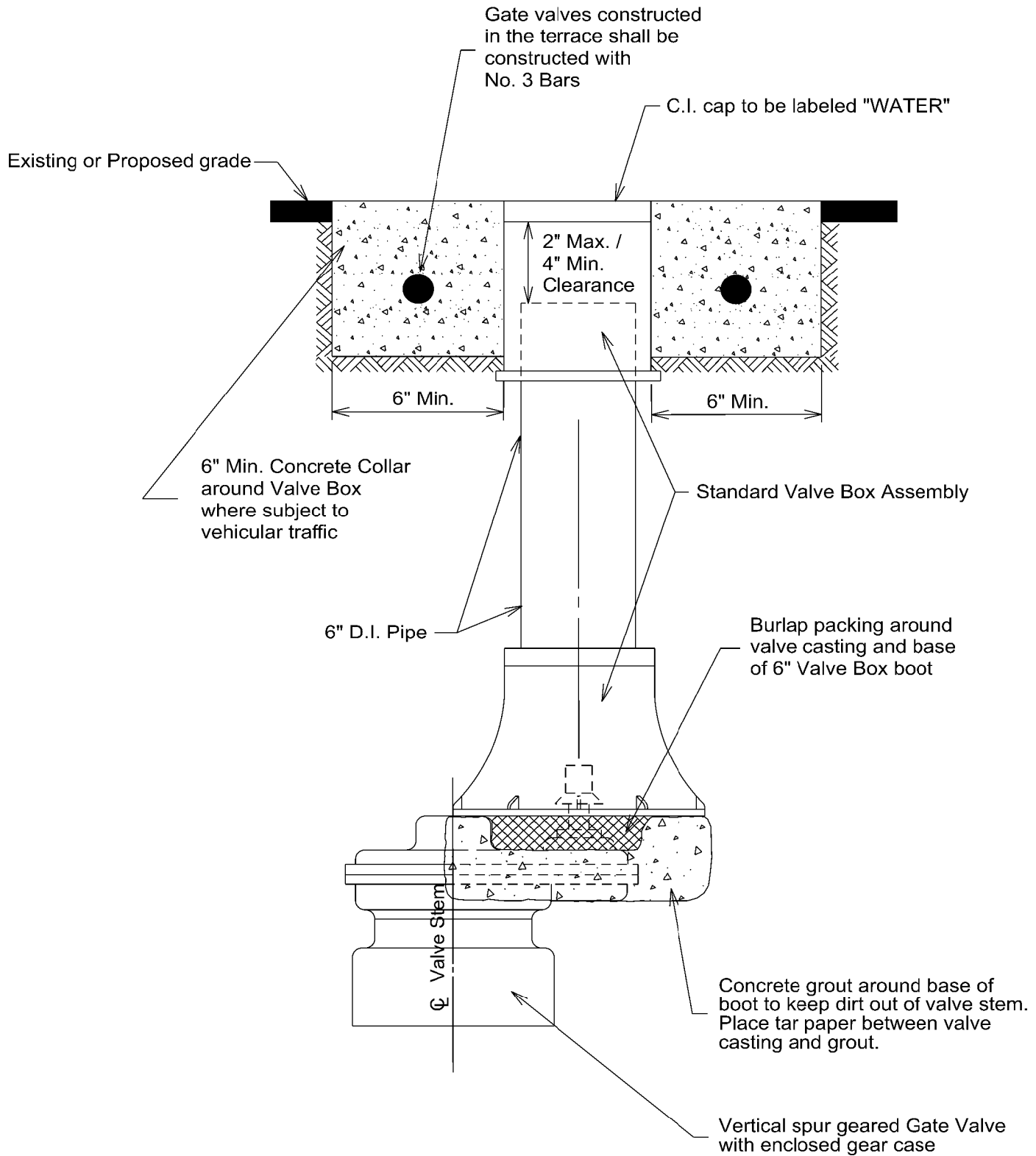

Note: All concrete to be 3,000 psi

PROPERTY OF SAN ANTONIO WATER SYSTEM SAN ANTONIO, TEXAS	INSTALLATION OF GEARED VERTICAL GATE VALVE WITH VALVE BOX COMPLETE	APPROVED	REVISED
		MARCH 2008	AUG 2019
		DD-828-03	SHEET 1 OF 1

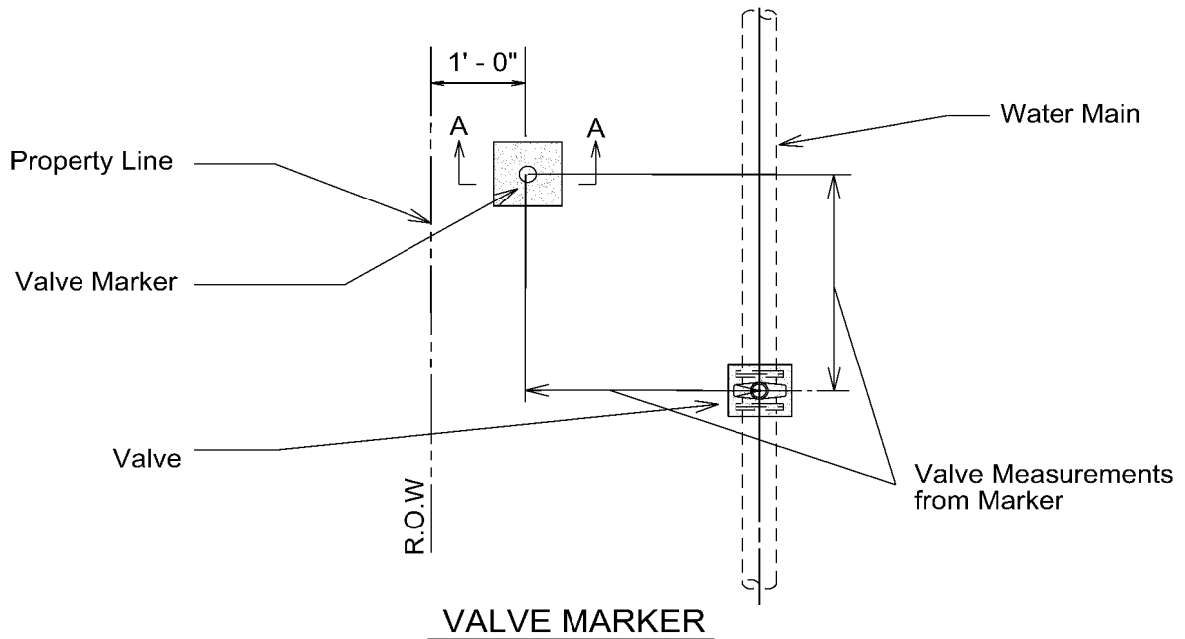

VALVE MARKER

Notes:

1. Valve Marker is 3" Steel pipe painted as shown
2. Valve Measurements shall be referenced to Marker
3. SAWS Decal shall be noted on the marker and facing the direction of the valve.

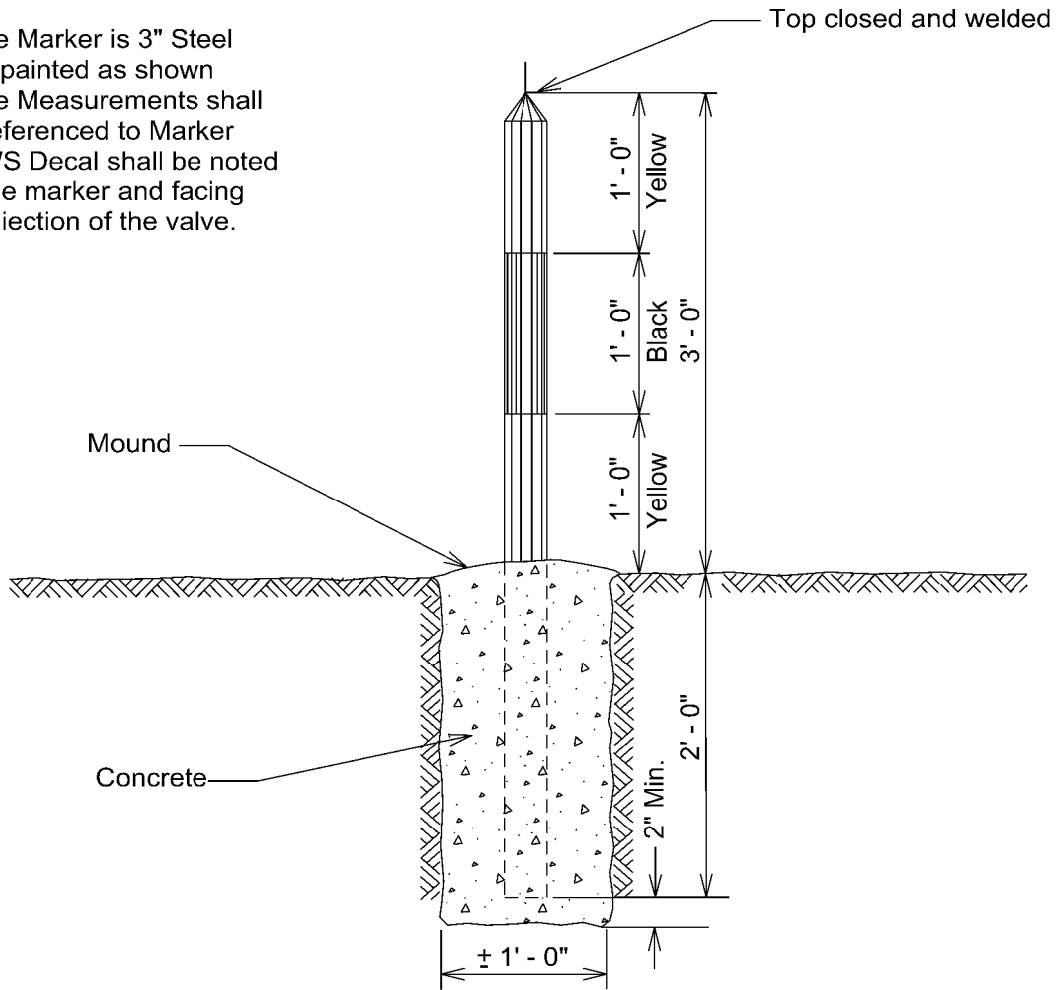

SECTION A-A