

TYPICAL DUCT BANK SECTION  
N.T.S.

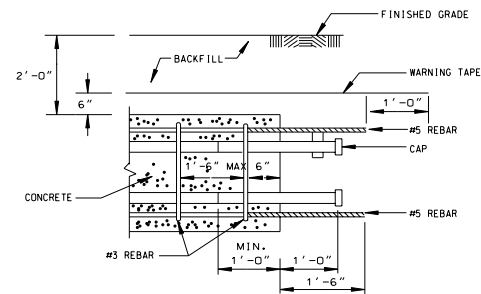

CONDUIT STUBOUT  
N.T.S.

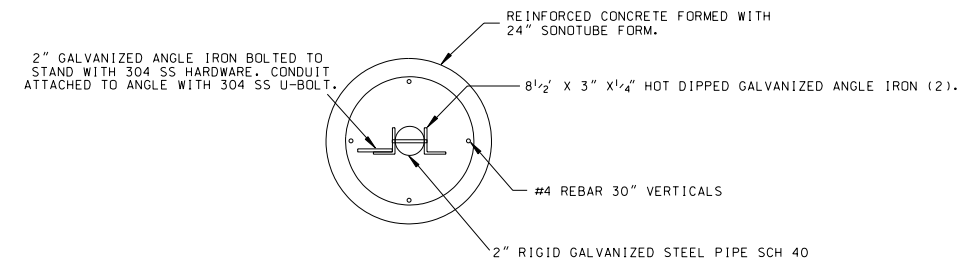

PLAN VIEW ANTENNA POST & FOUNDATION  
N.T.S.

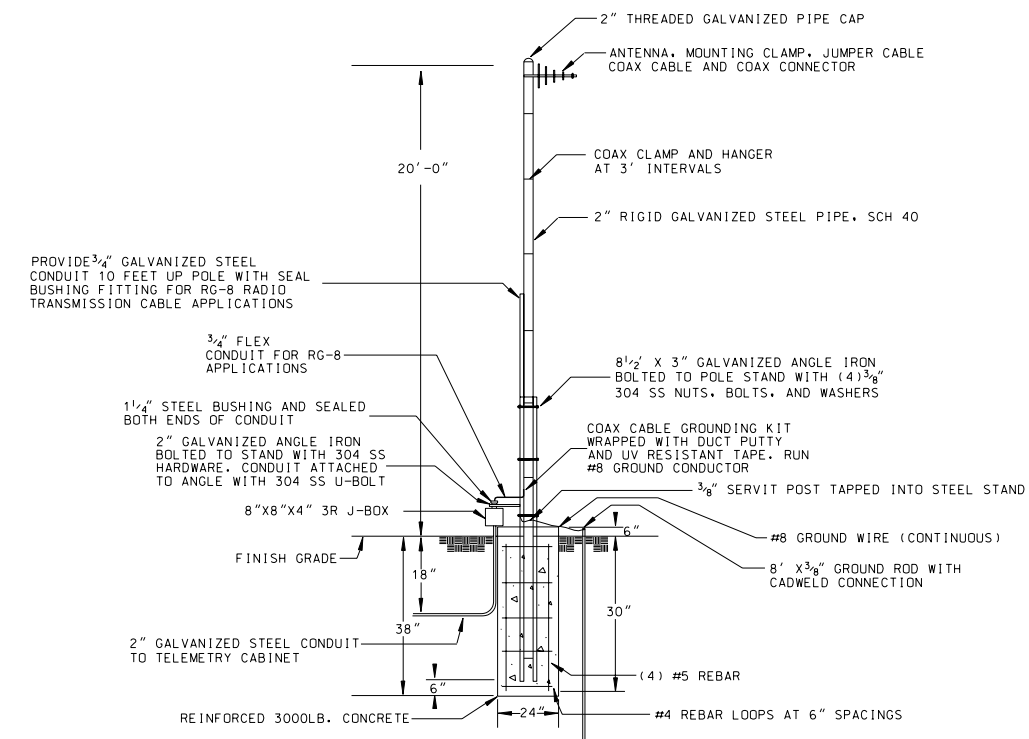

SIDE VIEW ANTENNA POST & FOUNDATION  
N.T.S.

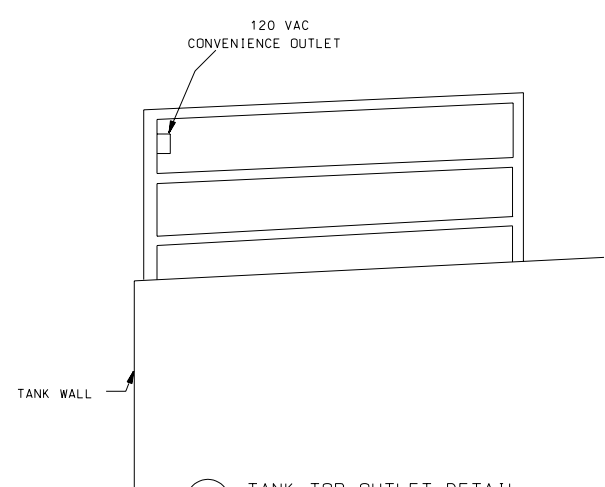

TANK TOP OUTLET DETAIL  
N.T.S.

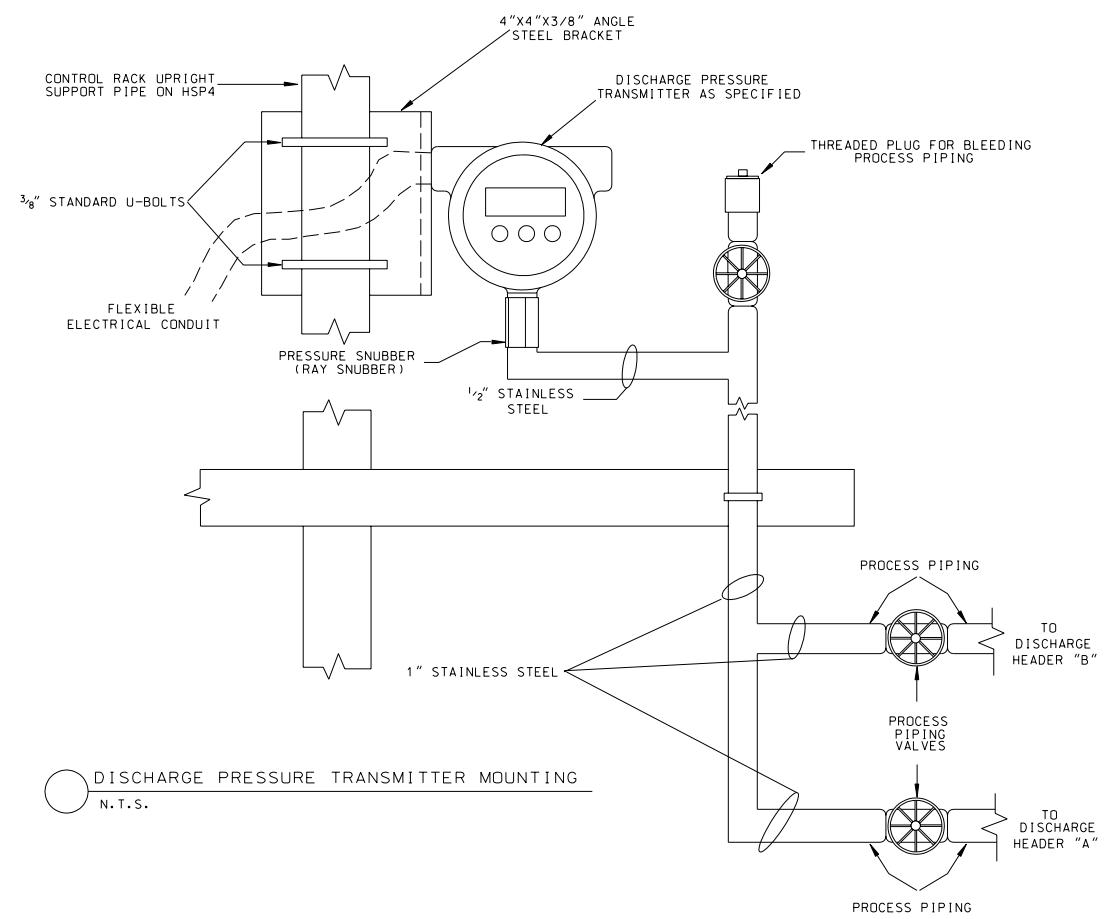

DISCHARGE PRESSURE TRANSMITTER MOUNTING  
N.T.S.

No.	Revision	Drawn	Approved	Date
Revisions				
<b>DESIGN STANDARDS PUMP STATION</b> MISCELLANEOUS DETAILS				
Developer		SAN ANTONIO WATER SYSTEMS		
Cont.		Budget Proj.		
SUBMITTED GRUBB ENGINEERING, INC.				
APPROVED				
Map No.				Sheet
Section No.				
Dr. rdg Ch		Job No.		E23